

### 255L Series Heavy Duty Gas Line Regulators

Suitable for high flow gas pipeline and switchover. Built with an internal balance structure and large diaphragm to ensure a large output flow while maintaining a low pressure drop.

#### Features

- Internal balancing mechanism
- Brass body
- Working Temperature: -40 ~ 140 °F (-40 ~ 60 °C)
- DN 12.5 connections
- Cleaned for oxygen service per CGA 4.1
- 3" Diaphragm

#### Materials

- Body: Brass
- Seat: EPDM
- Diaphragm: EPDM



255L-125(PIP)

#### Flow Data

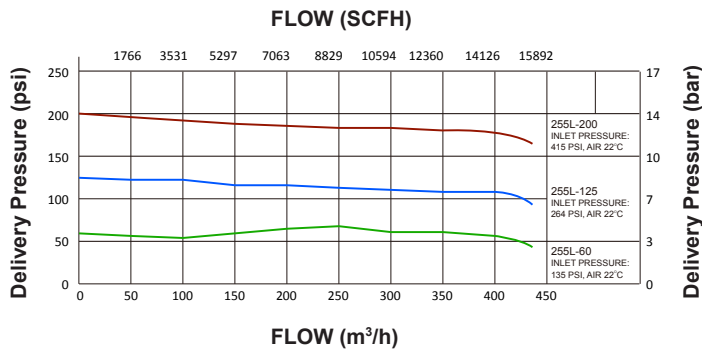

#### Dimensions

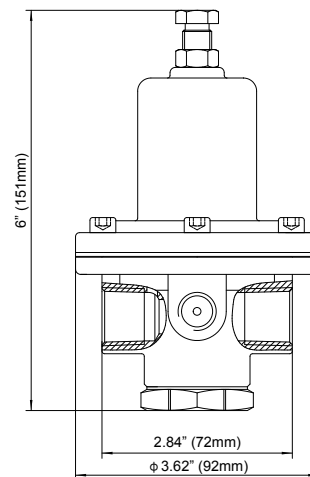

#### Ordering Information

Model Number	Max. Inlet Pressure psi (bar)	Outlet Pressure psi (bar)	Inlet / Outlet Connection
255L-60(PIP)	500 (35)	5~60 (0.4~4.1)	1/2" NPT(F)
255L-125(PIP)	500 (35)	40~125 (2.8~8.6)	1/2" NPT(F)
255L-200(PIP)	500 (35)	100~200 (6.9~13.8)	1/2" NPT(F)